



Safety sensors with RFID technology ST G series



ST G series safety sensors with RFID technology

Introduction



Pizzato Elettrica presents the latest development in the ST series of RFID safety sensors, already well known to and appreciated by machinery manufacturers and users. The new ST G series sensors incorporate all of the technology used in the traditional ST D series of sensors, in an even more compact housing.

The symmetry of the housing allows the same sensor to be used on both left and right doors; by simply rotating the sensor onto itself. The 22 mm fixing pattern and compact external dimensions allow replacement of traditional magnetic sensors with a more sophisticated RFID safety sensor, without having to modify the clearances between holes on the machine.

The monolithic housing – free of resins for encapsulation – can be used in even the most aggressive of environments; such as, for example, in the food and pharmaceuticals sector.

Maximum safety with a single device

PL e + SIL 3

The sensors of the ST G series are constructed with redundant electronics. As a result, the maximum PL e and SIL 3 safety levels can still be achieved through the use of a single device on a guard. This avoids expensive wiring in the field and allows faster installation. Inside the control cabinet, the two electronic safety outputs must be connected to a safety module with OSSD inputs or to a safety PLC.

Series connection of multiple sensors

One of the most important features of the ST G series from Pizzato Elettrica is the possibility of connecting up to 32 sensors in series, while still maintaining the maximum safety level (PL e) laid down in EN 13849-1.

This connection type is permissible in safety systems which have a safety module at the end of the chain that monitors the outputs of the last ST G sensor.

The fact that the PL e safety level can be maintained even with 32 sensors connected in series demonstrates the extremely secure structure of each sensor of the ST G series.

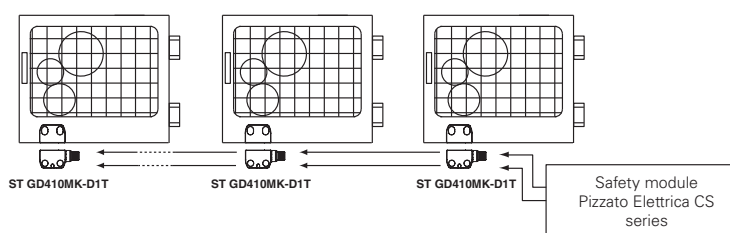

Series connection with other devices

PL e + SIL 3

The ST G series features two safety inputs and two safety outputs, which can be connected in series with other Pizzato Elettrica safety devices. This option allows the creation of safety chains containing various devices. For example, stainless steel hinge switches (HX BEE1 series), RFID sensors (ST D or ST G series) and guard-locking switches (NG or NS series) can be connected in series while still maintaining the maximum PL e and SIL 3 safety levels.

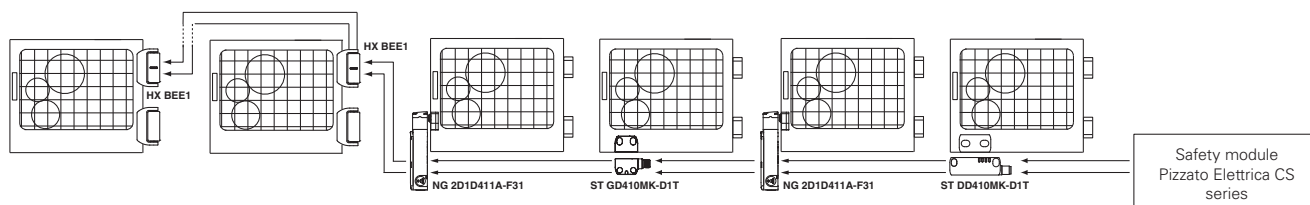

High level coded actuators



The ST G series is provided with an electronic system based on RFID technology to detect the actuator. This allows to provide each actuator with different coding and makes it impossible to tamper with a device by using another actuator of the same series. Millions of different coding combinations are possible for the actuators. They are therefore classified as high level coded actuators, according to EN ISO 14119.

Protection degrees IP67 and IP69K

IP69K IP67

These devices are designed to be used in the toughest environmental conditions and they pass the IP67 immersion test acc. to EN 60529. They can therefore be used in all environments where maximum protection degree of the housing is required. Due to their special design, these devices are suitable for use in equipment subjected to cleaning with high pressure hot water jets. These devices meet the IP69K test requirements according to ISO 20653 (water jets with 100 bar and 80°C).

Wide actuation range

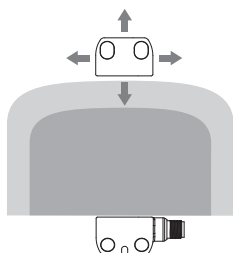

By utilising the properties of RFID technology, the sensors of the ST G series have a wide actuation range, making them very well suited for applications with large tolerances or where mechanical properties change over time.

Actuation from many directions

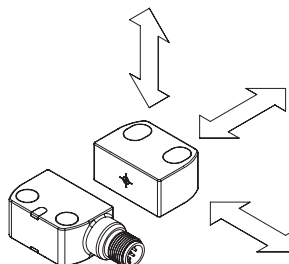

The sensors of the ST G series were designed to be activated from various directions, thereby providing the customer with maximum flexibility when positioning the sensors on the guards.



Symmetrical housing

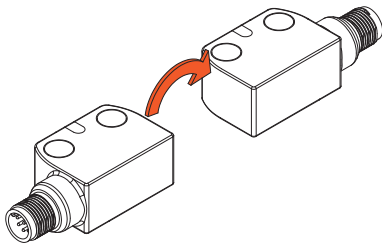

it into the desired direction; thus eliminating the need to order differently coded products.

Both sensor and actuator are perfectly symmetrical, and can therefore be attached to the machine frame in any orientation.

This feature allows the user to decide the side on which the cable or connector should exit, according to the sensor mounting position, by simply rotating

Multicolour signalling LED



The ST G series sensors have a multicolour RGB signalling LED, which, using suitable transparent lenses, can be seen from both sides of the device. This allows fast, immediate diagnostics of the input and output operating states.

This makes it possible to quickly identify the interruption points in the safety chain, active devices, open guards, and any internal device errors – all of which can be identified simply and intuitively.

Protection against tampering

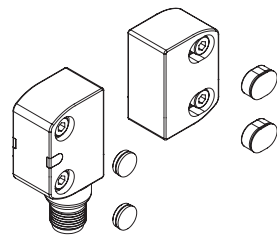

Each sensor and actuator of the ST G series is supplied complete with snap-on protection caps to be applied on the holes of the fixing screws. Not only do the caps prevent dirt from accumulating and simplify cleaning, they also block access to the fastening screws of the actuator. As a result, standard screws can be used instead of tamper-proof screws.

Compact dimensions, standard hole spacing

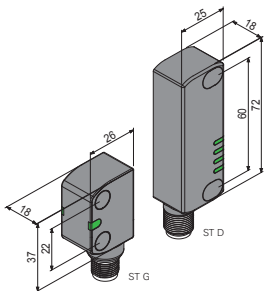

The extremely compact sensor and actuator dimensions allow installation in all types of guards. This makes the ST G series a safety device that can be adapted to the widest variety of applications.

When compared to the traditional ST D series, the distance between the holes for the fixing screws has been reduced to just 22 mm. This is the distance already in use with the magnetic SR A sensors by Pizzato Elettrica, and recognised as a market standard for safety sensors. These characteristics make the ST G series the ideal choice for technological upgrade of traditional safety devices without guard lock.

External device monitoring

EDM On request, the switch can be supplied with EDM function (External Device Monitoring). In this case, the switch itself checks the proper function of the devices connected to the safety outputs. These devices (usually relays or safety contactors) must send a feedback signal to the EDM input, which checks that the received signal is consistent with the state of the safety outputs.

Programmability

Programmable ST G sensor versions are available. Here, with a simple and brief operation, the sensor can be programmed to recognise the code of a new actuator.

By activating a special input, the sensor is switched to a safe state, during which it waits for a new code to be accepted. As the actuator approaches, the ST G sensor performs a number of checks on the code being received, whereby the code must adhere to certain parameters of RFID technology.

If the checks are successful, the sensor uses LEDs to signal the successful completion of the procedure.

After programming has been completed, the sensor only recognises the code of the last programmed actuator, thereby preserving the safety level and the reliability of the system in which it is installed.

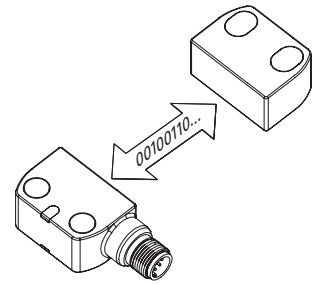

Laser engraving

All devices are marked using a dedicated indelible laser system. These engravings are therefore suitable for extreme environments too. Thanks to this system that does not use labels, the loss of plate data is prevented and a greater resistance of the marking is achieved over time.



Insensitivity to dirt

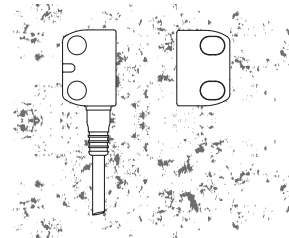

The sensors are completely sealed and retain their safety characteristics even in the presence of dirt or deposits (not ferromagnetic material). This characteristic, combined with the design without recesses, makes them particularly suitable for use in the food industry.

Compatible with all SM ••T actuators

Designed for use in conjunction with the SM G•T series actuators, together they form a complete assembly, even from an aesthetic point of view; the ST G sensors are also compatible with all actuators available for the ST series, with either high or low coding level.

This is particularly useful in applications where the actuator must have specific characteristics; such as, for example, increased activation distance (SM E•T actuators), compact installation dimensions (SM L•T actuators), or fixing holes positioned on two different sides (SM D•T).

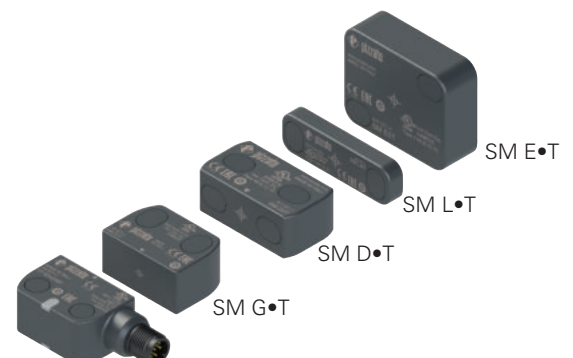

ST G series safety sensors with RFID technology

Selection diagram

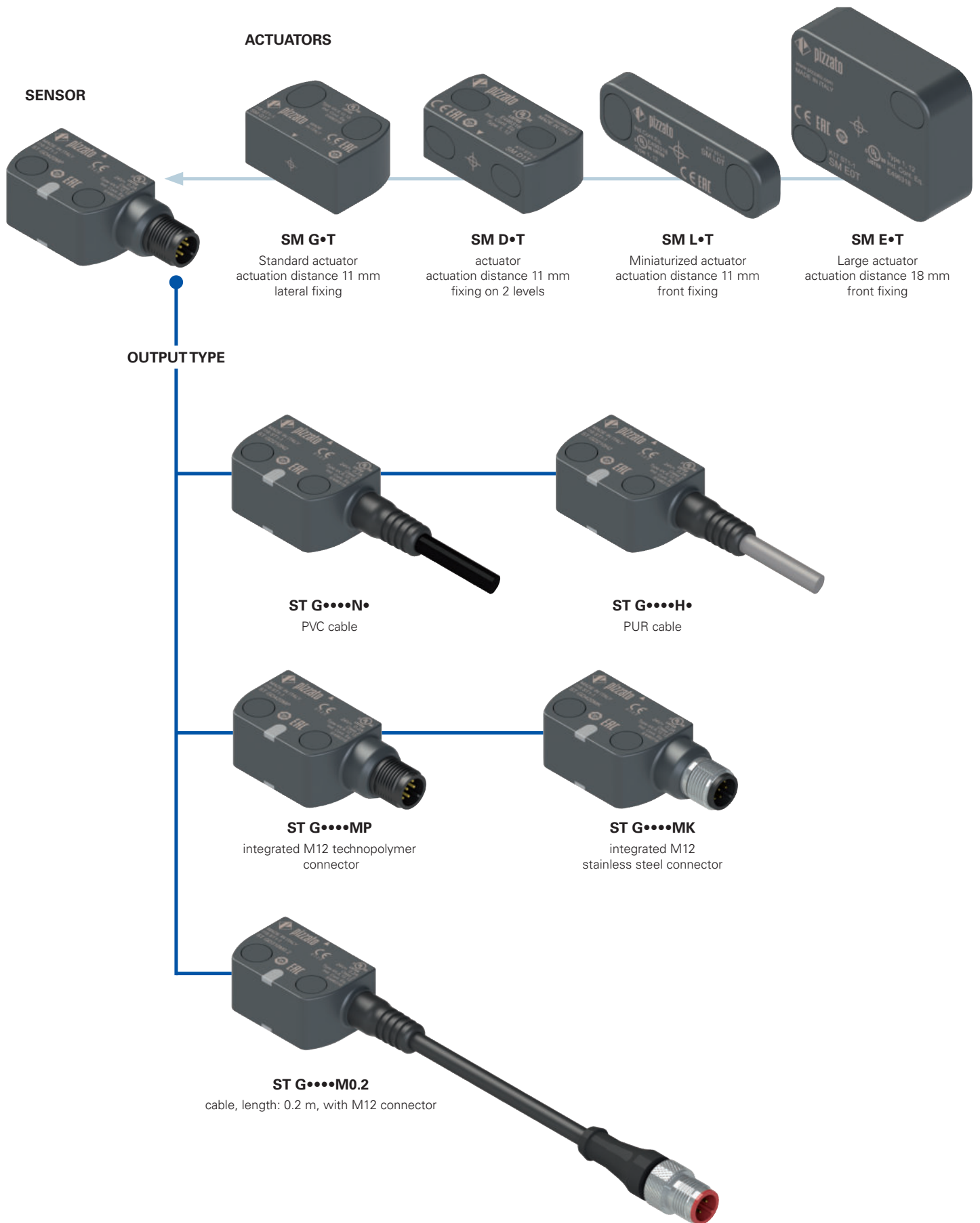



Attention! The feasibility of a code number does not mean the effective availability of a product. Please contact our sales office.

Code structure for sensor with actuator

ST GD420N2-G1T

Inputs and outputs					
	OS safety outputs	O signalling outputs	IS safety inputs	I programming inputs	EDM inputs
21	2	1	-	-	-
31	2	1	2	-	-
42	2	1	2	1	-
51	2	1	2	-	1
61	2	1 (inverted)	-	-	-
71	2	1 (inverted)	2	-	-
82	2	1 (inverted)	2	1	-

Note: versions 21, 31, 51, 61, 71 are only supplied together with an actuator

Supply voltage	
0	24 Vdc

Cable or connector type	
N	PVC cable, IEC 60332-1-2 oil resistant (standard)
H	PUR cable, halogen free (not available with versions ST G•2•••• and ST G•6••••)
M	M12 connector

Coding level	
0T	low level coded actuator the sensor recognises any type •0T actuator
1T	high level coded actuator the sensor recognises one single type •1T actuator

Actuator design	
G	Standard actuator Dimensions 37 x 26 x 18 mm, hole spacing 22 mm
D	Actuator with fixing on 2 levels Dimensions 45 x 25 x 18 mm, hole spacing 27 mm
E	Large actuator Dimensions: 40 x 50 x 16 mm
L	Miniaturized actuator Dimensions 53 x 16 x 7 mm, hole spacing 40 mm

Connection type	
0.2	cable, length: 0.2 m, with M12 connector (standard)
1	cable, length: 1 m
2	cable, length: 2 m (standard)
...
10	cable, length: 10 m
P	integrated M12 technopolymer connector (standard)
K	integrated M12 stainless steel connector

Code structure for single sensor **Attention!** The feasibility of a code number does not mean the effective availability of a product. Please contact our sales office.

ST GD420N2

Inputs and outputs				
	OS safety outputs	O signalling outputs	IS safety inputs	I programming inputs
42	2	1	2	1
82	2	1 (inverted)	2	1

Supply voltage	
0	24 Vdc

Connection type	
0.2	cable, length: 0.2 m, with M12 connector (standard)
1	cable, length: 1 m
2	cable, length: 2 m (standard)
...
10	cable, length: 10 m
P	integrated M12 technopolymer connector (standard)
K	integrated M12 stainless steel connector

Cable or connector type	
N	PVC cable, IEC 60332-1-2 oil resistant (standard)
H	PUR cable, halogen free
M	integrated M12 connector

Attention! Individual sensors are initially programmed with the code of the actuators with low coding level •0T.

Code structure for actuator **Attention!** The feasibility of a code number does not mean the effective availability of a product. Please contact our sales office.

SM G1T

Actuator design	
G	Standard actuator Dimensions 37 x 26 x 18 mm, hole spacing 22 mm
D	Actuator with fixing on 2 levels Dimensions 45 x 25 x 18 mm, hole spacing 27 mm
E	Large actuator Dimensions: 40 x 50 x 16 mm
L	Miniaturized actuator Dimensions 53 x 16 x 7 mm, hole spacing 40 mm

Coding level	
0T	low level coded actuator the sensor recognises any type •0T actuator
1T	high level coded actuator the sensor recognises one single type •1T actuator



Main features

- Actuation without contact, using RFID technology
- Digitally coded actuator
- Protection degrees IP67 and IP69K
- Symmetrical housing with universal fixing orientation
- Multicolour signalling LED

Quality marks:



UL approval: E496318
 EC type examination certificate: M6A 075157 0027
 TÜV SÜD approval: Z10 075157 0026
 EAC approval: RU C-IT.YT03.B.00035/19

In compliance with standards:

IEC 61508-1, IEC 61508-2, IEC 61508-3,
 IEC 61508-4, EN ISO 13849-1, EN ISO 13849-2,
 EN ISO 14119, EN 62061, EN 60947-5-3,
 EN 60947-5-2, EN 60947-1, EN 61326-1,
 EN 61326-3-1, EN 61326-3-2, EN 50581,
 ETSI 301 489-1, ETSI 301 489-3, ETSI 300 330-2,
 UL 508, CSA 22.2 No.14

Compliance with the requirements of:

Machinery Directive 2006/42/EC,
 EMC Directive 2014/30/EC,
 Directive 2014/53/EU - RED,
 RoHS Directive 2011/65/EU,
 FCC Part 15.

Connection with safety modules for safety applications:

Connection with safety modules
 CS AR-05•••••; CS AR-06•••••; CS AR-08•••••;
 CS AT-0•••••; CS AT-1•••••; CS MP•••••.
 When connected to the safety module, the sensor can be classified as a control circuit device up to PDBB (EN 60947-5-3).
 The system can be used in safety circuits up to PL e/SIL 3/category 4 in accordance with EN ISO 13849-1.

Technical data

Housing

Housing made of glass fibre reinforced technopolymer, self-extinguishing.
 Versions with integrated cable 5 x 0.25 mm² or 8 x 0.25 mm², length 2 m, other lengths on request.
 Versions with integrated M12 connector, plastic or stainless steel, AISI 304.
 Versions with 0.2 m cable length and M12 connector, other lengths on request.
 Protection degree: IP67 acc. to EN 60529

IP69K acc. to ISO 20653
 (Protect the cables from direct high-pressure and high-temperature jets)

General data

SIL (SIL CL) up to: SIL 3 acc. to EN 62061
 Performance Level (PL) up to: PL e acc. to EN ISO 13849-1
 Safety category up to: cat. 4 acc. to EN ISO 13849-1
 Interlock, no contact, coded: type 4 acc. to EN ISO 14119
 Level of coding acc. to EN ISO 14119: high with SM •1T actuators
 low with SM •0T actuators

Safety parameters:

MTTF_D: 1551 years
 PFH_D: 1,19E-09
 DC: High
 Mission time: 20 years
 Ambient temperature for sensors without cable: -25 ... +70 °C
 Ambient temperature for sensors with cable: see table page 6
 Storage and transport temperature: -35 ... +85 °C
 Vibration resistance: 10 gn (10 ... 150 Hz) acc. to IEC 60068-2-6
 Shock resistance: 30 gn; 11 ms acc. to EN 60068-2-27
 Pollution degree: 3
 Screw tightening torque: 0.8 ... 1 Nm

Power supply electrical data

Rated operating voltage U_o SELV: 24 Vdc -15% ... +10%
 Supply voltage tolerance: ± 15% of U_o
 Operating current at U_o voltage:
 - minimum: 20 mA
 - with all outputs at maximum power: 550 mA
 Rated insulation voltage U_i: 32 Vdc
 Rated impulse withstand voltage U_{imp}: 1.5 kV
 External protection fuse: 1 A type Gg or equivalent device
 Overvoltage category: III

Electrical data of IS1/IS2/I3/EDM inputs

Rated operating voltage U_{e1}: 24 Vdc
 Rated current consumption I_{e1}: 2.5 mA
 Switching time EDM state (t_{EDM}): 500 ms

Electrical data of OS1/OS2 safety outputs

Rated operating voltage U_{e2}: 24 Vdc
 Output type: PNP type OSSD
 Maximum current per output I_{e2}: 0.2 A
 Minimum current per output I_{m2}: 0.5 mA
 Thermal current I_{th2}: 0.2 A
 Utilization category: DC13; U_{e2}=24 Vdc, I_{e2}=0.2 A
 Short circuit detection: Yes
 Overcurrent protection: Yes
 Internal self-resettable protection fuse: 0.3 A
 Duration of the deactivation impulses at the safety outputs: < 300 µs
 Permissible maximum capacitance between outputs: < 200 nF
 Permissible maximum capacitance between output and ground: < 200 nF
 Response time upon deactivation of input IS1 or IS2: < 15 ms
 Response time upon actuator removal: < 50 ms
 Availability time: 2 s

Electrical data of O3 signalling output

Rated operating voltage U_{e3}: 24 Vdc
 Output type: PNP
 Maximum current per output I_{e3}: 0.1 A
 Utilization category: DC13; U_{e3}=24 Vdc; I_{e3}=0.1 A
 Short circuit detection: No
 Overcurrent protection: Yes
 Internal self-resettable protection fuse: 120 mA

Actuation data

	Actuators SM G•T, SM D•T, SM L•T,	SM E•T actuators
Assured operating distance S _{ao} :	8 mm	14 mm
Assured release distance S _{ar} :	20 mm	26 mm
Rated operating distance S _{ri} :	11 mm	18 mm
Rated release distance S _{ri} :	13 mm	20.5 mm
Repeat accuracy:	≤ 10 % s _n	
Differential travel:	≤ 20 % s _n	
RFID transponder frequency:	125 kHz	
Max. switching frequency:	1 Hz	
Distance between two sensors:	min. 50 mm	



Features approved by UL

Electrical Ratings: 24 Vdc Class 2, 0,20 A
 Environmental Ratings: Types 1, 4X, 6, 12, 13
 Accessory for series ST for actuator switch series SM D, SM E, SM G, SM L.
 The models provided with M12 Connector may be provided with the mating-Connectors-part (with Cord attached).

Please contact our technical department for the list of approved products.

Features approved by TÜV SÜD

Supply voltage: 24 Vdc, -15% ... +10%
 Protection degree: IP67 and IP69K
 Ambient temperature: -25°C ... +70°C
 -35°C ... +85°C (T8 option)
 Storage and transport temperature: -25°C ... +85°C
 PL, category: PL e, category 4

In compliance with standards: Machine Directive 2006/42/EC, EN ISO 13849-1:2015, EN 60947-5-3:2013, EN 61508-1:2010 (SIL 3), EN 61508-2:2010 (SIL 3), EN 61508-3:2010 (SIL 3), EN 61508-4:2010 (SIL 3), IEC 62061:2005 (SIL CL3), IEC 62061:2005/AMD1:2012, IEC 62061:2005/AMD2:2015 (SIL CL3).

Please contact our technical department for the list of approved products.

Selection table for sensors with high level coded actuators

OS safety outputs	O signalling outputs	IS safety inputs	I programming inputs	EDM inputs	Programmable	with 0.2 m cable length and M12 connector	with cable	with M12 connector
2	1	-	-	-	-	/	ST GD210N•-G1T	ST GD210MP-G1T
2	1	2	-	-	-	ST GD310M0.2-G1T	ST GD310N•-G1T	ST GD310MP-G1T
2	1	2	1	-	•	ST GD420M0.2-G1T	ST GD420N•-G1T	ST GD420MP-G1T
2	1	2	-	1	-	ST GD510M0.2-G1T	ST GD510N•-G1T	ST GD510MP-G1T

Selection table for sensors

OS safety outputs	O signalling outputs	IS safety inputs	I programming inputs	EDM inputs	Programmable	with 0.2 m cable length and M12 connector	with cable	with M12 connector
2	1	2	1	-	•	ST GD420M0.2	ST GD420N•	ST GD420MP

Selection table for actuators

Level of coding acc. to ISO 14119	Standard actuator	Standard actuator with fixing on 2 levels	Miniaturized actuator	Large actuator
	low	SM G0T	SM D0T	SM L0T
high	SM G1T	SM D1T	SM L1T	SM E1T

Type •0T actuators are all encoded with the same code. This implies that a sensor associated with an actuator type •0T can be activated by other actuators type •0T.

Type •1T actuators are always encoded with different codes. This implies that a sensor associated with an actuator type •1T can be activated only by a specific actuator. Another •1T type actuator will not be recognised by the sensor until a new association procedure is carried out (reprogramming). After reprogramming, the old actuator type •1T will no longer be recognized. Reprogramming of the actuator can be performed repeatedly.

Ambient temperature for sensors with cable

Cable features	Connection type	Output with cable			Output with cable and M12 connector	
	Cable type	N	N	H	8x0.25 mm ²	5x0.25 mm ²
Conductors		8x0.25 mm ²	5x0.25 mm ²	8x0.25 mm ²	8x0.25 mm ²	5x0.25 mm ²
Application field		General	General	General, mobile installation	General	General
In compliance with standards		03VV5-H	03VV5-H	03E7Q-H	03VV5-H	03VV5-H
Sheath		PVC OIL RESISTANT	PVC OIL RESISTANT	PUR Halogen Free	PVC OIL RESISTANT	PVC OIL RESISTANT
Self-extinguishing		IEC 60332-1-2 UL 758:FT1 CEI 20-22 II	IEC 60332-1-2 UL 758:FT1 CEI 20-22 II	IEC 60332-1-2 UL 758:FT1	IEC 60332-1-2 UL 758:FT1 CEI 20-22 II	IEC 60332-1-2 UL 758:FT1 CEI 20-22 II
Oil resistant		UL 758 CSA 22.2 N°210	UL 758 CSA 22.2 N°210	UL 758 CSA 22.2 N°210	UL 758 CSA 22.2 N°210	UL 758 CSA 22.2 N°210
Max. speed		50 m/min	50 m/min	300 m/min.	50 m/min	50 m/min
Max. acceleration		5 m/s ²	5 m/s ²	30 m/s ²	5 m/s ²	5 m/s ²
Minimum bending radius		90 mm	75 mm	70 mm	90 mm	75 mm
Outer diameter		6 mm	6 mm	6 mm	6 mm	6 mm
End stripped		80 mm	80 mm	80 mm	/	/
Copper conductors		Class 6 IEC 60228	Class 6 IEC 60228	Class 6 IEC 60228	Class 6 IEC 60228	Class 6 IEC 60228
Engraving		6275	6267	6284	6275	6267
Ambient temperature	Cable, fixed installation	-25°C ... +70°C	-25°C ... +70°C	-25°C ... +70°C	-25°C ... +70°C	-25°C ... +70°C
	Cable, flexible installation	-15°C ... +70°C	-15°C ... +70°C	-25°C ... +70°C	-15°C ... +70°C	-15°C ... +70°C
	Cable, mobile installation	-15°C ... +70°C	-15°C ... +70°C	-25°C ... +70°C	-15°C ... +70°C	-15°C ... +70°C
Approvals		CE cULus TUV EAC	CE cULus TUV EAC	CE cULus TUV EAC	CE cULus TUV EAC	CE cULus TUV EAC

→ The 2D and 3D files are available at www.pizzato.com

ST G series safety sensors with RFID technology

Complete safety system

The use of complete and tested solutions guarantees the electrical compatibility between the sensors of the ST series and the safety modules from Pizzato Elettrica, as well as high reliability. The sensors have been tested with the modules listed in the adjacent table.

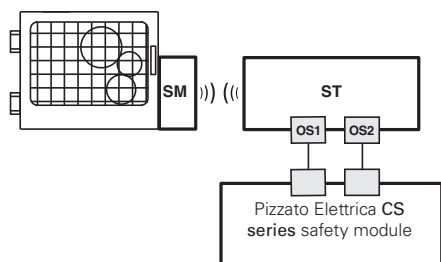

ST sensors can be used as individual devices provided that the outputs be evaluated by a Pizzato Elettrica safety module (see table for combinable safety modules).

Compatible safety modules

Sensors	Safety modules	Safety module output contacts		
		Instantaneous safety contacts	Delayed safety contacts	Signalling contacts
ST G.....	CS AR-05.....	3NO	/	1NC
	CS AR-06.....	3NO	/	1NC
	CS AR-08.....	2NO	/	/
	CS AT-0.....	2NO	2NO	1NC
	CS AT-1.....	3NO	2NO	/
	CS MP.....	see page 277 of the General Catalogue Safety		
	CS MF.....	see page 305 of the General Catalogue Safety		

All ST series sensors can be connected, provided that compatibility is checked, to safety modules or safety PLCs with OSSD inputs.

Connection in series with safety modules

Multiple ST series sensors can be **connected in series**, so as to simplify the safety system wiring. In this configuration, the safety outputs of the last sensor in the chain must be evaluated by a Pizzato Elettrica CS series safety module (see table for compatible safety modules).

Each ST sensor is additionally equipped with a **signalling output**, which – depending on the version – is activated or deactivated when the respective guard is closed. This information can be managed – according to the specific requirements of the implemented system – by a PLC or by a Pizzato Elettrica CS MP series safety module, which allows control of both safety and signalling outputs.

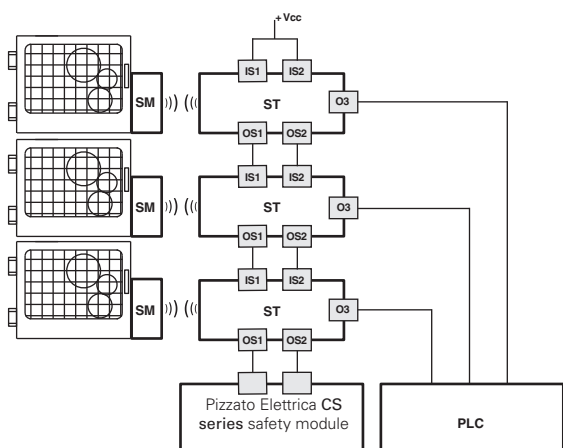

Connection with safety module and PLC

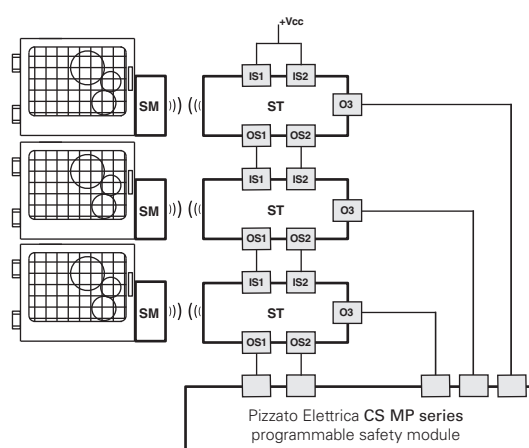

Connection with programmable safety module

Internal operating block diagram

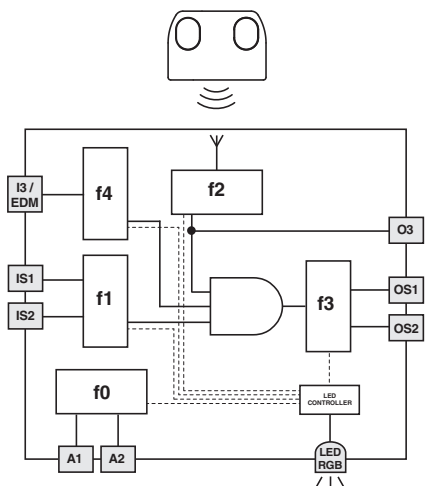

The adjacent diagram illustrates five logical, linked sub-functions of the sensor.

Function f0 is a basic function and includes the monitoring of the power supply as well as internal, cyclical tests.

Function f1 monitors the status of the inputs, whereas function f2 monitors the position of the actuator in the detection area.

Function f3 is intended to activate or deactivate the safety outputs and check for any faults or short circuits in the outputs.

The f4 function verifies the coherence of the EDM signal during safety output state changes (in versions with EDM input), or monitors the activation state of the programming input, activating the actuator replacement procedure (in versions with I3 programming input).

The safety-related function, which combines the sub-functions mentioned above, only activates the safety outputs if the input signals are correctly applied and the actuator is located within the safe zone.

The state of each function is displayed via signalling LED illumination and colour change. This immediately communicates the overall sensor state to the operator.



Operating states

The multicolour signalling LED, which can be seen from both sides of the device, provides easy and intuitive verification of sensor operating state.



GREEN LED
Normal operating state, with actuator inside detection zone.



YELLOW LED
Normal operating state, with actuator outside detection zone.



RED LED
Error state: the error type is indicated to the user via LED illumination sequences and colour variations.



PURPLE LED
Programming state during new actuator identification procedure.

Limit activation zone and safe activation zone

When aligning the sensor with the actuator, the multicolour signalling LED changes colour to indicate to the operator whether the actuator is in the limit activation zone or in the safe activation zone.

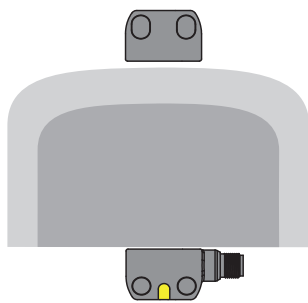

The sensor has power, the inputs are enabled, the outputs are disabled. The actuator is outside of the actuation zone. The LED is illuminated constant yellow.

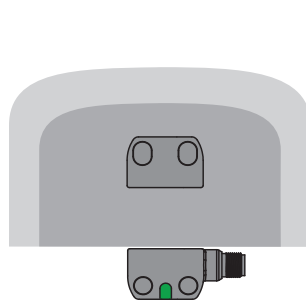

If the actuator is moved inside the safe activation zone (dark grey area), the sensor activates the outputs. The LED is illuminated constant green.

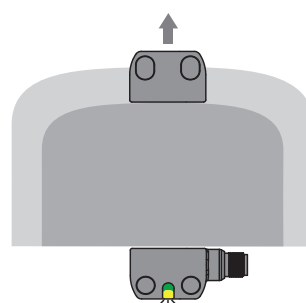

When the actuator leaves the safe zone, the sensor keeps the safety outputs enabled. Entry into the limit activation zone (light grey area) is, however, indicated by the yellow LED flashing intermittently.

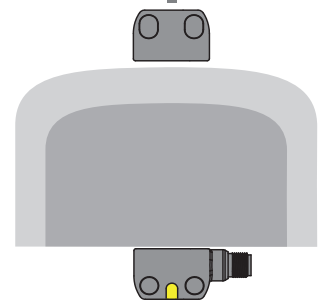

When the actuator leaves the limit activation zone, the sensor disables the outputs. The signalling LED illuminates again constant yellow.

External device monitoring (EDM)

The ST G•510** version, in addition to maintaining the operating and safety characteristics of the ST series, allows control of **forcibly guided NC contacts of contactors or relays** controlled by the safety outputs of the sensor itself. This check is carried out by monitoring the EDM input (External Device Monitoring as defined in EN 61496-1) of the sensor.

As an alternative to the relays or contactors you can use Pizzato Elettrica expansion modules CS ME-03. See page 263 of the General Catalogue Safety.

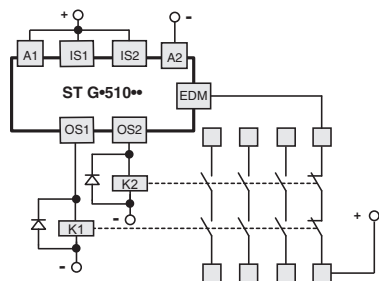

The EDM version, which is equipped with the IS safety inputs, **can be used at the end of a series of ST sensors, up to a maximum number of 32 devices**, while maintaining the maximum PL e safety level according to EN 13849-1.

For specific applications, this solution allows you to dispense with the safety module connected to the last device in the chain.

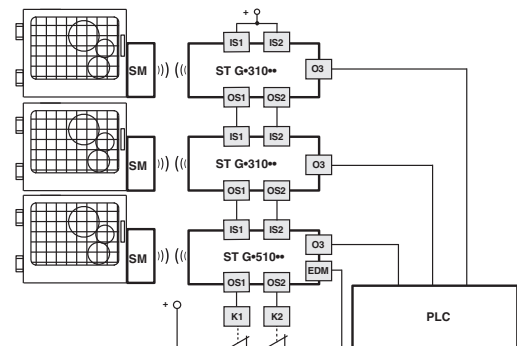

O3 output inverted

Using versions with inverted O3 signalling output (articles ST G•6****, ST G•7****, ST G•8****) allows checking of the actual electrical connection of the sensor by an external PLC. The O3 output will be activated when the actuator is removed and the OS safety outputs are switched off.

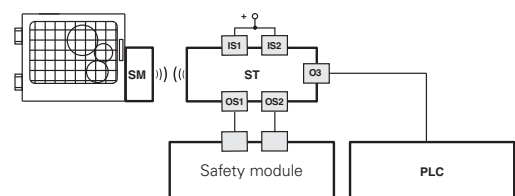

ST G series safety sensors with RFID technology

Connection with safety modules

Connections with CS AR-08•••• safety modules

Input configuration with monitored start

2 channels / Category 4 / up to SIL 3 / PL e

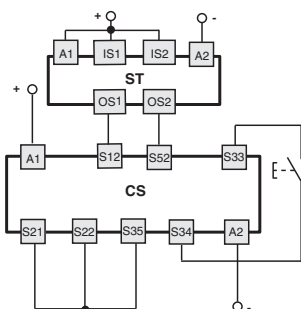

Connections with CS AR-05•••• / CS AR-06•••• safety modules

Input configuration with manual start (CS AR-05••••) or monitored start (CS AR-06••••)

2 channels / Category 4 / up to SIL 3 / PL e

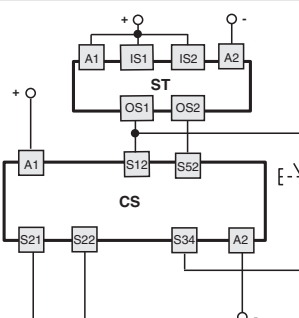

Connections with CS AT-0••••• / CS AT-1••••• safety modules

Input configuration with monitored start

2 channels / Category 4 / up to SIL 3 / PL e

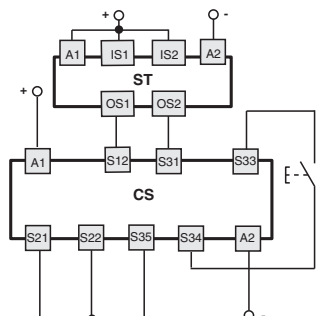

For features of the safety modules see page 213 of the General Catalogue Safety 2019-20

Connection with safety module CS MP••••0

The connections vary according to the program of the module

Category 4 / up to SIL 3 / PL e

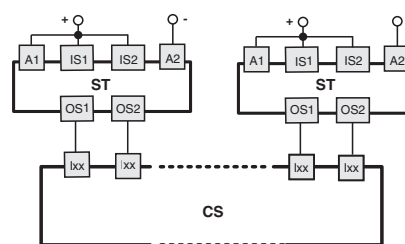

For application examples, see page 276 of the General Catalogue Safety 2019-20

Internal device connections

5-pole versions

ST G•2••••, ST G•6••••

M12 connector	Cable	Connection
1	brown	A1 (+)
2	white	OS1
3	blue	A2 (-)
4	black	OS2
5	grey	O3

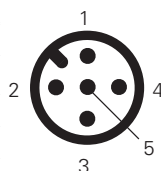

8-pole versions

ST G•3••••, ST G•4••••, ST G•5••••, ST G•7••••, ST G•8••••

M12 connector	Cable	Connection
1	white	A1 (+)
2	brown	IS1
3	green	A2 (-)
4	yellow	OS1
5	grey	O3
6	pink	IS2
7	blue	OS2
8	red	not connected ^(a) I3 ^(b) EDM ^(c)

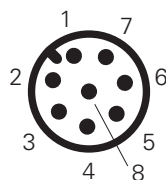

^(a) for articles ST G•3••••, ST G•7••••.

^(b) for articles ST G•4••••, ST G•8••••.

^(c) for articles ST G•5••••.

Legend

A1-A2: supply

IS1-IS2 Safety inputs

OS1-OS2: safety outputs

O3: signalling output

I3: programming input

EDM: input for monitoring of NC contacts of the contactors

NOTE: Versions with customised pin assignments are available on request.

For female connectors, see page 321 of the General Catalogue Safety 2019-20

Series connection

To simplify series connections of the devices, various M12 connectors are available that allow complete wiring.

This solution significantly reduces installation times while at the same time maintaining the maximum safety levels PL e and SIL 3.

For further information see page 326 of the General Catalogue Safety 2019-20

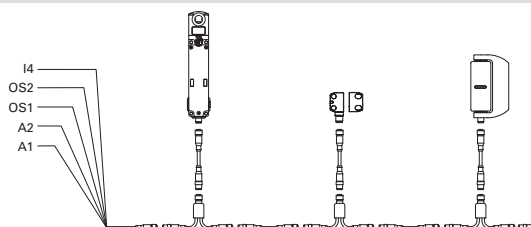



Operating distances for SM G•T, SM D•T, SM L•T actuators

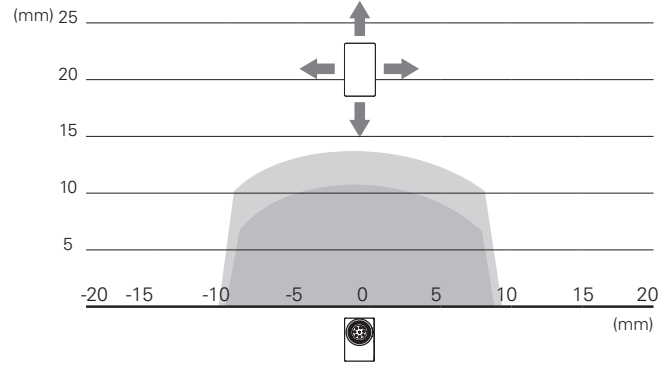
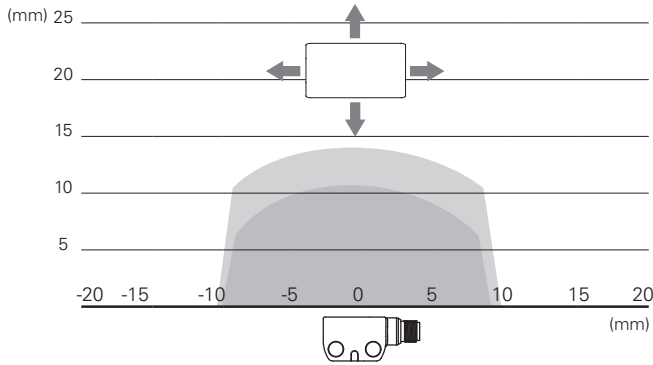

Operating distances for SM E•T actuators

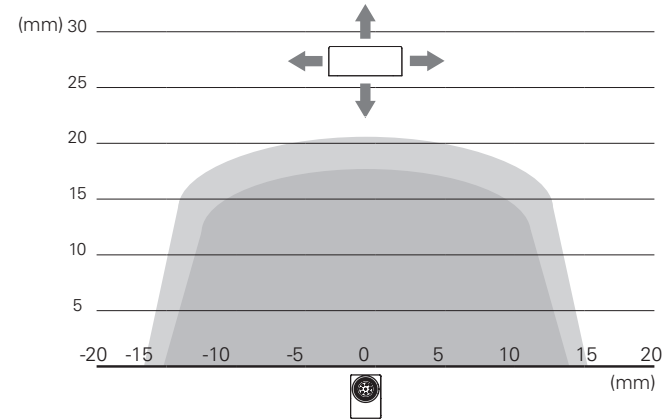
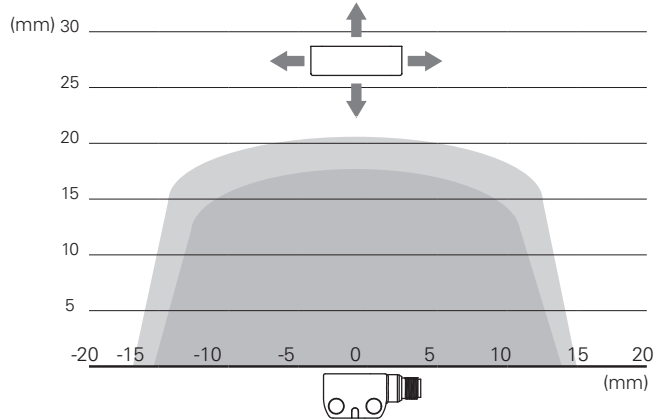

Legend:

Rated operating distance s_n (mm)

Rated release distance s_r (mm)

Note: The progress of the activation areas is for reference only; the possible application on ferromagnetic surfaces can reduce the operating distances.

Dimensional drawings

ST G•••N• sensor with cable

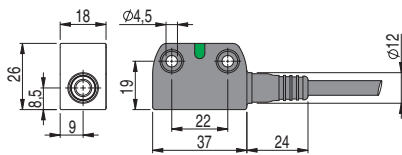

ST G•••MP sensor with M12 connector

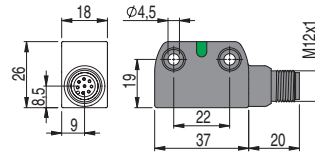

ST G•••M0.2 sensor with cable and M12 connector

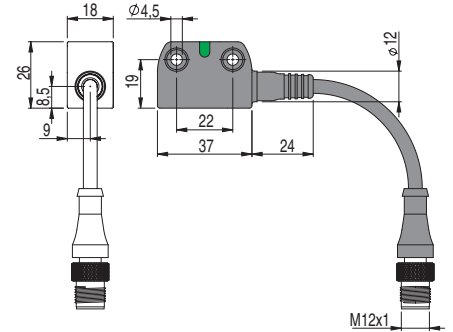

SM G•T actuator

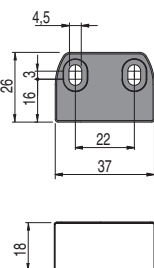

SM D•T actuator

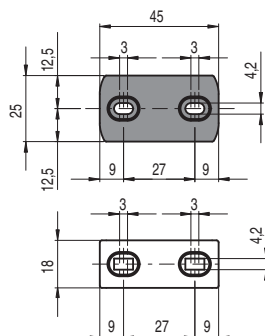

SM L•T actuator

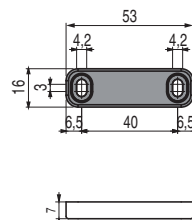

SM E•T actuator

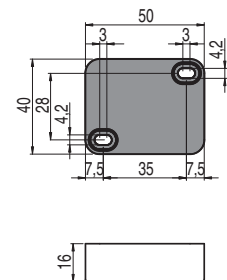

All values in the drawings are in mm

→ The 2D and 3D files are available at www.pizzato.com



General Catalogue
Detection



General Catalogue
HMI



General Catalogue
Safety



General Catalogue
Elevators



Website
www.pizzato.com



Pizzato Elettrica s.r.l. Via Torino, 1 - 36063 Marostica (VI) Italy
Telephone +39 0424 470 930
E-mail: info@pizzato.com
Website: www.pizzato.com

ZE FGL27A20-ENG

